

WIRING DIAGRAM

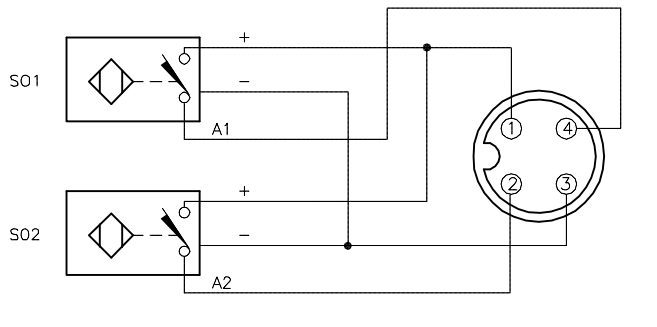

SPECIFICATIONS PER SENSOR

PASS SPEED	≤ 10 m/s
HYSTERESIS	≤ 1mm
TEMPERATURE DRIFT	≤ 0.1mm
MIN. ABSOLUTE REPEAT ACCURACY	≥ ±0.1mm
OPERATING TEMPERATURE	-25°C to +70°C (-13°F to +158°F)
RATED OPERATIONAL VOLTAGE	10-30 VDC
MAX. RIPPLE	≤ 10%
DC RATED OPERATIONAL CURRENT	≤ 150 mA PER SENSOR
NO-LOAD CURRENT	≤ 30 mA
RESIDUAL CURRENT	≤ 0.1 mA PER SENSOR
MAX. SWITCHING FREQUENCY	≤ 1.0 kHz
RATED INSULATION VOLTAGE	≤ 0.5 kV
OUTPUT FUNCTION	NORMALLY OPEN, 3-WIRE, PNP
SHORT-CIRCUIT PROTECTION	YES, CYCLIC
MAX. VOLTAGE DROP	≤ 1.8 V
WIRE BREAKAGE PROTECTION	INCORPORATED
REVERSE POLARITY PROTECTION	INCORPORATED
HOUSING MATERIAL	PLASTIC, PP
ACTIVE FACE MATERIAL	PLASTIC, PP
CABLE	∅3.0, TPU
VIBRATION	55 Hz, 1 mm AMPLITUDE (IN ALL 3 PLANES)
SHOCK	30 g, 11 ms
DEGREE OF PROTECTION	IP67
SWITCHING STATUS INDICATION	LED, YELLOW
INCLUDED IN SCOPE OF SUPPLY	CABLE CLIP

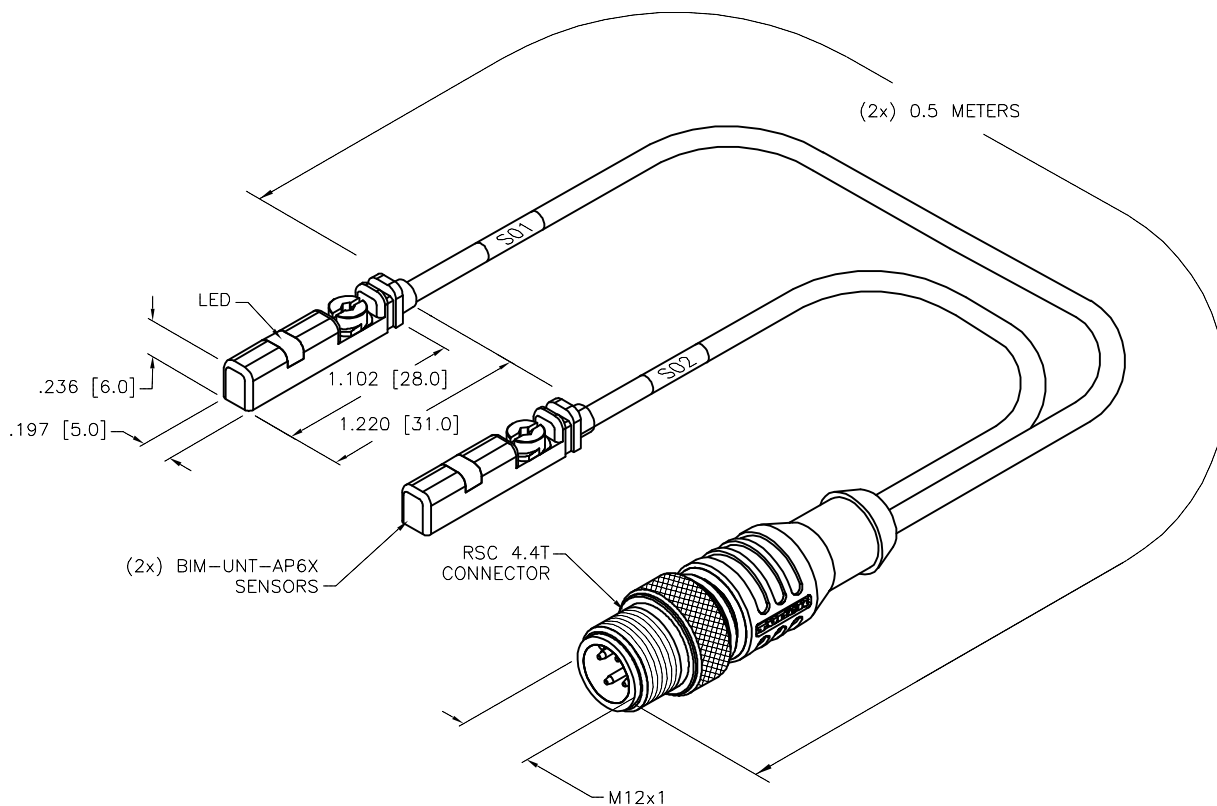

SOURCE DRAWING - FOR REFERENCE ONLY

RELATED DOCUMENTS 1. 2. 3. 4.	3RD ANGLE PROJECTION 	THIS DRAWING IS CONFIDENTIAL AND THE PROPERTY OF TURCK INC. USE OF THIS DOCUMENT WITHOUT WRITTEN PERMISSION IS PROHIBITED.		3000 CAMPUS DRIVE MINNEAPOLIS, MN 55441 1-800-544-7769 (763) 553-7300 (763) 553-0708 fax www.turck.us	
		MATERIAL  SEE SPECIFICATIONS	DRFT KMY APVD J.M.	DATE 08/14/13 SCALE 1=1.0	DESCRIPTION BIM-UNT-2AP6X-0.5-RSC4.4T
FINISH  SEE SPECIFICATIONS	ALL DIMENSIONS DISPLAYED ON THIS DRAWING ARE FOR REFERENCE ONLY  CONTACT TURCK FOR MORE INFORMATION	UNIT OF MEASUREMENT <b>INCH [ MILLIMETER ]</b>		IDENTIFICATION NO. 46857217	REV D
D UPDATE COUPLING NUT RDS 04/19/18 56903	REV DESCRIPTION BY DATE ECO NO.	DO NOT SCALE THIS DRAWING		FILE: 46857217	SHEET 1 OF 1

D	UPDATE COUPLING NUT	RDS	04/19/18	56903
REV	DESCRIPTION	BY	DATE	ECO NO.